

Technical Data

Product Range

"L" Shaped Panels

Height: as required up to a maximum of 4.00m
Width: 1.20m
Depth: 175mm for panels up to 2.00m high
 225mm for panels from 2.10m high to 4.00m high.

Straight Panels

Height: as required up to a maximum of 2.00m
Width: 1.15m
Depth: 200mm

Parapet Units

Standard Parapet Size:

Height: 800mm
Width: 1150mm
Depth: 500mm

Manufacture

Rocwall "L" shaped and Straight panels together with Parapet units are manufactured from Grade C40 concrete. Both 'L' shaped and straight panels have a natural stone facing on one side. Parapet units are stone faced on both sides.

All standard Rocwall units are manufactured according to the following.

Cement: OPC BS 12: 1996.

Aggregates: BS882: 1992

Mix design: BS5328: 1997
 Table 9: Grade C40

Durability: BS5328: 1997
 Severe to Table 5

Sulphate resistance:
 BS5328: 1997
 Table 7: Class 2

Steel reinforcement:
 BS5400: Part 4: 1990

Minimum cement content:
 370kg/m³

Maximum aggregate size:
 10mm

Dimensional tolerances:

Dimensional tolerances for Rocwall units are based on the guidance given in BS 8110: Part 1: 1997. Any special requirements concerning dimensions should be made known by the Engineer at the pre-contract stage and accompanied by drawings, as recommended in Clause 6.2.8.3.

Complimentary Products:

Purpose designed units manufactured to Clients specification together with a variety of complimentary products can be supplied. Please consult Sales Department for further details.

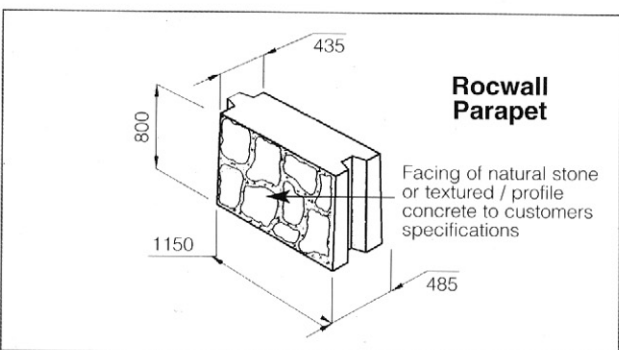
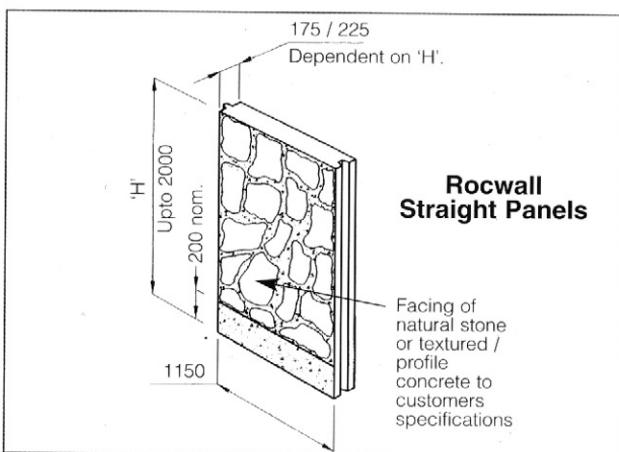
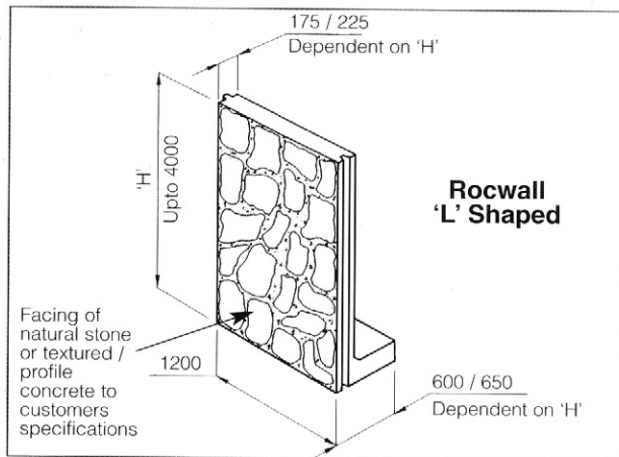

For technical advice & quotations contact:

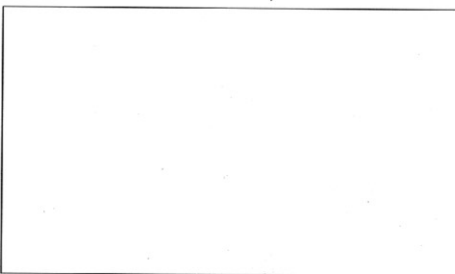

Ruthin Precast Concrete Limited
 Quarryfields,
 Ruthin,
 Denbighshire, LL15 2UG.
 Tel: 01824 702493
 Fax: 01824 704527

The Company's policy is one of continuous development and product improvement. Information contained in this leaflet is subject to alteration without notice.

Concrete products may suffer the temporary phenomenon of efflorescence. This is in no way detrimental to the performance of the material and responsibility cannot be accepted for its occurrence.